



Castle Metals®

Stainless Steel Bars

Quik Guide

Your Foremost Provider of Specialty Products and Services

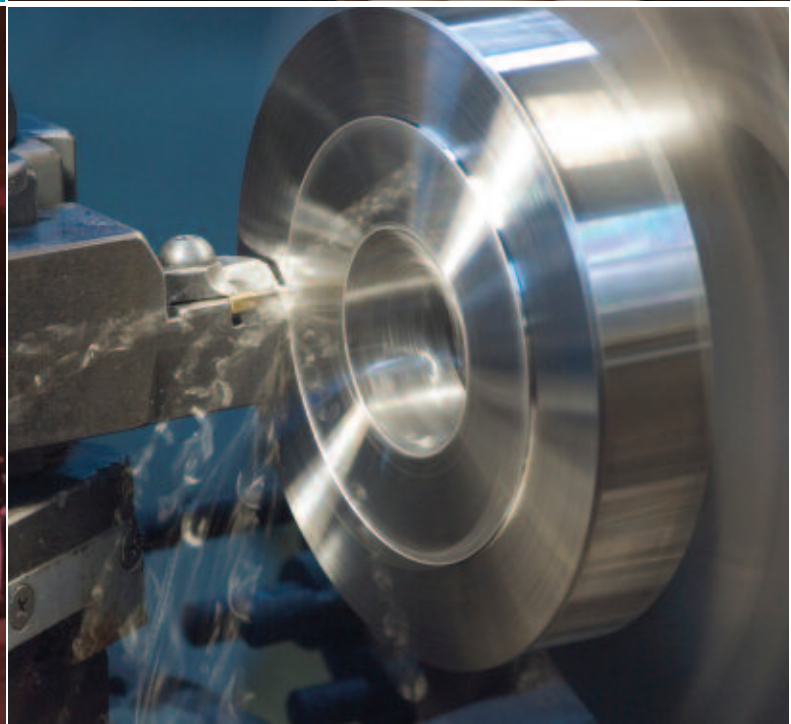
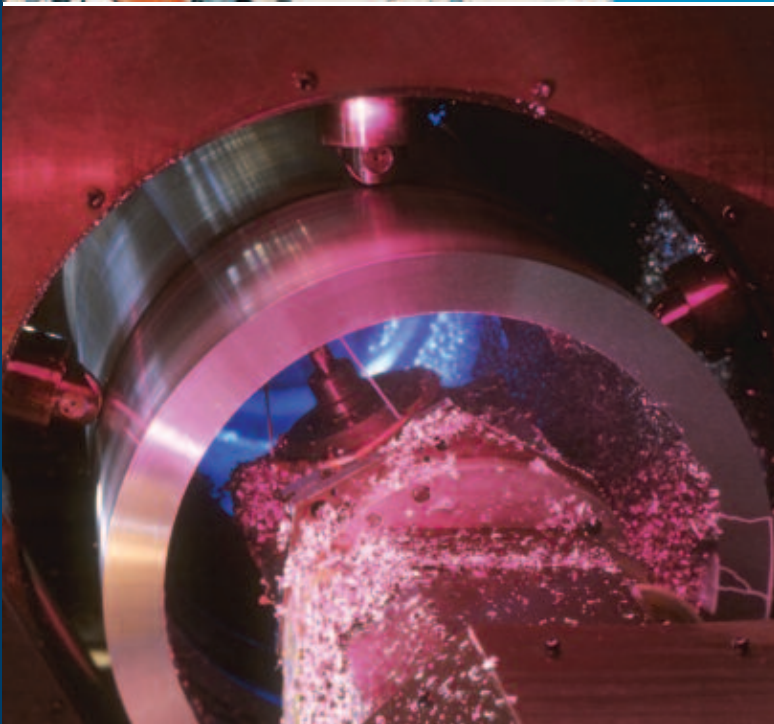
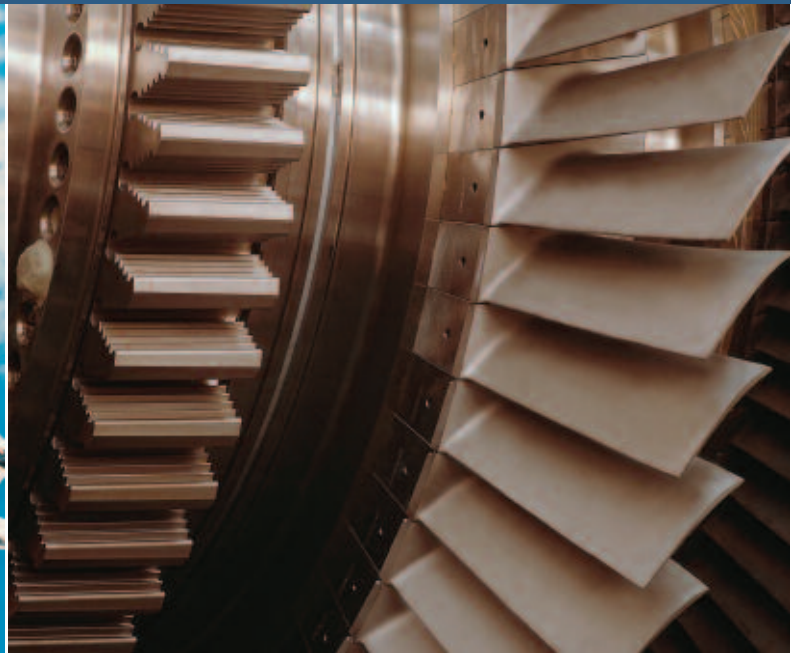

Stainless Bar Minimum Recommended Stock Removal

Cold Drawn; Up to & Incl. 5/16" Over 5/16"	Rounds - Hexagons - Squares .003 per side except 440-C 1% of Diameter per Side
Centerless Ground: All Ground **Defect Free** within the Standard Size Tolerances Example: 1-1/2" Rd. TOL is ±.003 Material must not have any defect under -.003	
Rough Turned: All "R.T." sizes are produced on the plus side. Material must be defect free on size. Example: 5" Rd. HR-RT must be defect free at 5"	

Above information provided by AL TECH SPECIALTY STEEL CORPORATION

HP-A&P Flats & Squares and Cold Drawn Flats Recommended Machining Allowances

(A) SPECIFIED WIDTH	(B) Removal From Thickness					(C) REMOVAL FROM WIDTH- EACH SURFACE
	1/8-1/2"	1/2-1"	1-2"	2-3"	3-4"	
Up to 1" Incl.	.008	.010	—	—	—	.015
Over 1-2" Incl.	.012	.015	.031	—	—	.031
Over 2-3" Incl.	.015	.020	.031	.047	—	.047
Over 3-4" Incl.	.015	.020	.031	.047	—	.062
Over 4-6" Incl.	.015	.020	.031	—	—	.093

(A) Select the "Width" first and then read across to:
 (B) Select the reading—this is the stock removal for the thickness per side
 (C) Continue across on same line for the readings for width
 (D) As measured from the minimum of the tolerance

Above information provided by AL TECH SPECIALTY STEEL CORPORATION

Stainless Bar Weight Formulas

ROUNDS

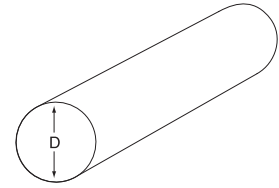

$$\text{Lbs. per lineal foot} = 2.67036 \times D^2$$

SQUARES

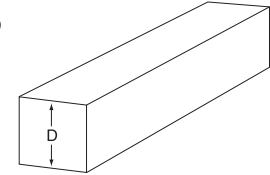

$$\text{Lbs. per lineal foot} = 3.4 \times D^2$$

FLATS

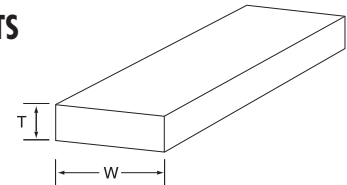

$$\text{Lbs. per lineal foot} = 3.4 \times T \times W$$

HEXAGONS

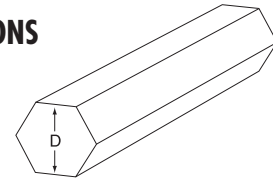

$$\text{Lbs. per lineal foot} = 2.9446 \times D^2$$

TOLERANCES-STAINLESS STEEL FLAT BARS

HOT ROLLED FLATS						EDGE CONDITIONED FLATS		
Thickness Variation	SPECIFIED WIDTHS					Thickness Specified	Thickness Tolerance	Width Tolerance
	To 1" Incl.	Over 1" to 2"	Over 2" to 4"	Over 4" to 6"	Over 6" to 8"			
1/8 – 1/2	± .008	± .012	± .015	± .015	± .016	*1/8"	±.010	+ .030 – .000
Over 1/2 to 1 Incl.	± .010	± .015	± .020	± .020	± .025	*3/16"	+ .020 – .010	+ .030 – .000
Over 1 to 2 Incl.	—	± .031	± .031	± .031	± .031	*1/4"	+ .020 – .010	+ .030 – .000
Width Variation						3/8"	+ .060 – .010	+ .0625 – .000
Over	.015	.031	.062	.093	.125	1/2"	+ .060 – .010	+ .125 – .000
Under	.015	.031	.031	.062	.156			







Quik Guide to

TYPE	SPECIFICATION ⁽³⁾					CHARACTERISTIC AND TYPICAL APPLICATION ⁽³⁾	COMPOSITION % ⁽²⁾						
	AISI GRADE Unified Numbering System(UNS)	AMS	ASTM	ASME	QQS		Chromium	Nickel	Carbon	Manganese	Sulfur	Others ⁽⁴⁾	
AUSTENITIC	203 (S20300)	5762	A-484 A-582	—	—	Low nickel. Free-machining modification of Type 303. Screw machine products; shafts; valves;bolts; bushings; nuts.	16.00-18.00	5.00-6.50	.08	5.00-6.50	.18-.35	Cu 1.75-2.25	
	303 (S30300) Available in CMQ [®] (17)	5640	A-484 A-582	—	764	Free-machining modification of Type 302/304, for heavier cuts. Screw machine products; shafts; valves; bolts; bushings; nuts.	17.00-19.00	8.00-10.00	.15	2.00	.15 Min.	—	
	304 ⁽⁵⁾ (S30400) Available in CMQ [®] (17)	5639	A-484 A-182 A-276 A-479	—	SA-182 SA-479	763	Low-carbon modification of Type 302 for restriction of carbide precipitation during welding. Chemical and food processing equipment; brewing equipment; cryogenic vessels; gutters; downspouts; flashings.	18.00-20.00	8.00-10.50	.08	2.00	.03	—
	304-L (S30403) Available in CMQ [®] (17)	5647	A-182 A-193 A-276	A-479 A-484	SA-182 SA-193 SA-479	763	Extra-low-carbon modification of Type 304 for further restriction of carbide precipitation during welding. Coal hopper linings; tanks for liquid fertilizer and tomato paste.	18.00-20.00	8.00-12.00	.03	2.00	.03	—
	316 ⁽⁵⁾ (S31600) Available in CMQ [®] (17)	5648	A-182 A-276 A-479	A-484 A-193	SA-182 SA-479 SA-193	763	Higher corrosion resistance than Types 302 and 304; high creep strength. Chemical and pulp handling equipment; photographic equipment; brandy vats; fertilizer parts; ketchup cooking kettles; yeast tubs.	16.00-18.00	10.00-14.00	.08	2.00	.03	Mo 2.00-3.00
	316-L ⁽⁵⁾ (S31603) Available in CMQ [®] (17)	5653	A-182 A-276 A-479	A-484 A-193	SA-182 SA-479 SA-193	763	Extra-low-carbon modification of Type 316. Welded construction where intergranular carbide precipitation must be avoided. Type 316 applications requiring extensive welding.	16.00-18.00	10.00-14.00	.03	2.00	.03	Mo 2.00-3.00
	321 (S32100)	5645	A-182 A-276	A-193 A-479	SA-182 SA-479 SA-193	—	Stabilized for weldments subject to sever corrosive conditions, and for service from 800 to 1600 F. Aircraft exhaust manifolds; boiler shells; process equipment; expansion joints; cabin heaters; fire walls; flexible couplings; pressure vessels.	17.00-19.00	9.00-12.00	.08	2.00	.03	Ti 5X (C+N) Min. to 0.70 Max.
	347 (S34700)	5646	A-182 A-276	A-193 A-479	SA-182 SA-193 SA-479	763	Similar to Type 321 with higher creep strength. Airplane exhaust stacks; welded tank cars for chemicals; jet engine parts.	17.00-19.00	9.00-13.00	.08	2.00	.03	Cb +Ta 10XC Min.
	316 Pump Shaft (S31600)	5648	A-276 A-479	—	—	763	Pump shaft quality bar is manufactured with special surface finish, close diameter tolerance, controlled mechanical properties and precision straightness.	16.00-18.00	10.00-14.00	.08	2.00	.03	Mo 2.00-3.00
	UNS (S20910) (XM-19)	5764	A-193 Grade B8R A-276 Grade XM-19 A-479 Grade XM-19	—	—	—	NITRONIC 50 [®] bars offer an excellent combination of high strength and corrosion resistance. This austenitic stainless steel has corrosion resistance better than Type 316 and 317, plus almost twice the yield strength of those grades.	20.50-23.50	11.50-13.50	.06	4.00-6.00	.03	N .20-.40 Mo 1.5-3.0 Cb .10-.30 V .10-.30
	NITRONIC 50 [®] (15) High Strength (S20910)	5764 (Chem Only)	A-193 Grade B8R (Chem Only) A-276 Grade XM-19 A-479 Grade XM-19	—	—	—	NITRONIC 50 [®] bars in the HS condition feature extremely high tensile and yield strength properties. These high mechanical properties are accomplished through cold working at the producing mill.	20.50-23.50	11.50-13.50	.06	4.00-6.00	.03	N .20-.40 Mo 1.5-3.0 Cb .10-.30 V .10-.30
	UNS (S21800)	5848	A-193 Grade B8S A-276 A-479	—	—	—	NITRONIC 60 [®] is an economical galling and wear resistant stainless steel. Better corrosion resistance than Type 304 and superior pitting resistance to Type 316 plus twice the yield strength of Type 304.	16.00-18.00	8.00-9.00	.10	7.00-9.00	.03	Si 3.50-4.50 N .08-.18

CMQ[®] is a registered service mark of A.M. Castle & Co.

Stainless Steel Bars

TYPICAL MECH. PROPERTIES					SIZE RANGE—INCHES						TYPE
Tensile 10 ³ P.S.I.	Yield 10 ³ P.S.I. .2% Offset	Elongation % 2 in.	Reduction in Area %	Hardness Brinell	 Rounds	 Hexagons	 Squares	 Flats	 Angles	AISI TYPE Unified Numbering System (UNS)	
85	35	45	55	160	3/16–2-5/16	3/16–1-11/16	—	—	—	203 (S20300)	
90	35	50	55	160	5/64–10	3/16–3	3/16–2	—	—	303 (S30300)	
85	35	60	70	170	3/32–20	3/8–3	1/4–2	T 1/8–1 W 1/2–6	T 1/8–3/8 W 3/4–4	304 ⁽⁵⁾ (S30403)	
75	30	60	70	160	3/16–20	—	—	—	—	304-L (S30403)	
80	35	55	65	170	1/8–20	7/16–2-1/2	3/16–1-1/2	T 3/16–1 W 1–4	T 1/8–3/8 W 1–3	316 ⁽⁵⁾ (S31600)	
75	30	55	65	160	3/16–20	—	—	T 3/16–1 W 1–4	T 1/8–3/8 W 1–4	316-L ⁽⁵⁾ (S31603)	
85	35	55	65	150	1/4–6	—	—	—	—	321 (S32100)	
90	30	50	65	170	1/8–5-1/2	—	—	—	—	347 (S34700)	
75	30	30	40	149	3/4–3-7/16	—	—	—	—	316 Pump Shaft (S31600)	
100	55	35	55	—	3/4–6	—	—	—	—	UNS (S20910) (XM-19)	
135	105	20	50	—	1-1/4–2	—	—	—	—	NITRONIC 50 ^{® (15)} High Strength (S20910)	
95	50	35	55	—	1-1/4–4	—	—	—	—	UNS (S21800)	

AUSTENITIC

(15) NITRONIC 50[®], NITRONIC 60[®] are registered trademarks of Armco Steel.

(16) SANMAC[®] is a registered trademark of SANDVIK Steel.

(17) Some Chemical and Mechanical properties may differ contact your sales representative for clarification.

Quik Guide to

TYPE	SPECIFICATION ⁽³⁾					CHARACTERISTIC AND TYPICAL APPLICATION ⁽³⁾	COMPOSITION % ⁽²⁾						
	AISI GRADE Unified Numbering System (UNS)	AMS	ASTM	ASME	QQS		Chromium	Nickel	Carbon	Manganese	Sulfur	Others ⁽⁴⁾	
MARTENSITIC	410 (S41000)	2303 5612 5613	A-276 A-479	A-314 A-193	SA-479 SA-193	763	General purpose heat treatable type. Machine parts; pump shafts; bolts; bushings; coal chutes; cutlery; fishing tackle; hardware; jet engine parts; mining machinery; rifle barrels; screws; valves.	11.5-13.50	—	.15	1.00	.03	—
	410 Quench & Dbl Temp.		A-484 NACE MR-01-91	API 6A	6A		Quenched and double tempered form of 410 for parts used in hydrogen sulfide.	11.5-13.50	—	.15	1.00	.03	—
	416⁽⁶⁾ (S41600) Available in CMQ ⁽¹⁷⁾	5610	A-484 A-582		—	764	Free-machinery modification of type 410; for heavier cuts. Aircraft fittings; bolts; nuts; fire extinguisher inserts; rivets; screws.	12.00-14.00	—	.15	1.25	.15 Min.	—
	416HT (S41600)	5610	A-484 A-582		—	764	Pre-hardened 416 for finished machine parts Rc26-32.	12.00-14.00	—	.15	1.25	.15 Min.	—
	440C (S44004)	5630	A-276		—	763	Yields highest hardnesses of hardenable stainless steels. Balls; bearings; races; nozzles; balls and seats for oil well pumps; valve parts.	16.00-18.00	.75	.95-1.20	1.00	.03	Mo .40-.65 Cu. 50
	440C BQ⁽⁷⁾ (S44004)	5630 5880	A-276 A-756		—	763	Martensitic stainless with high strength, corrosion resistance and hardness obtained by low temperature heat treatment. Gear; cams; cutlery; shafting; aircraft parts.	16.00-18.00	.75	.95-1.20	1.00	.03	Mo .40-.65 Cu. 50
	416 Pump Shaft (S41600)	5610	A-582		—	—	Pump shaft quality bar is manufactured with special surface finish, close diameter tolerance, controlled mechanical properties and precision straightness.	12.00-14.00	—	.15	1.25	.15 Min.	—
	420 Modified	—	A-370 E-23 E-112 A484		—	—	420 modified is an API 6A approved 13% chromium martensitic stainless steel intended for use in structural and pressure containing oil tool parts used in CO2 environments.	12.50-14.00	.20	.18-.22	1.00	.005	—
DUPLEX	2205 (S31803)	—	A-182 A-276		SA-182	—	2205 is a duplex (austenitic-ferritic) stainless steel possessing high strength and good resistance to stress corrosion used for heat exchangers, oil and gas industry equipment.	21.00-23.00	4.50-6.50	.03	2.00	.02	—
	2507 (S32750)	—	A-479 A-182 Grade F53 Chem & Mech.		—	—	2507 is a high-alloy duplex stainless steel with an optimal combination of high corrosion resistance and high mechanical strength. The mechanical strength is very high, even in comparison with other duplex steels.	25.00	7.00	.03	.30	.02	—
PRECIPITATION HARDENING	13Cr-8Ni⁽⁷⁾ (S13800)	5629 2300	A-564 (Grade XM-13)		—	—	High strength, ductility and toughness both longitudinally and transversely. Excellent general corrosion resistance as well as high degree of resistance to stress corrosion cracking. Aircraft structural components, landing gear parts, shafts, valves, fittings, fasteners and petrochemical applications.	12.25-13.25	7.5-8.5	.05	.20	.008	P. 010 Al .90-1.35 Mo 2.00-2.50
	15Cr-5Ni⁽⁷⁾ (S15500)	2300 5659	A-564 (Grade XM-12)		—	—	Martensitic stainless with high strength, corrosion resistance and hardness obtained by low temperature heat treatment. Gear; cams; cutlery; shafting; aircraft parts.	14.00-15.5	3.50-5.50	.07	1.00	.03	Cu 2.50-4.50 Cb+Ta .15-.45
	17Cr-4Ni⁽⁷⁾ (S17400) Cond. A Available in CMQ ⁽¹⁷⁾	2303 5643	A-564 (Type 630)		SA-564 (Type 630)	—	Similar to 15Cr-5Ni, but with slightly higher chromium content. Gears; springs; cutlery; fasteners; aircraft and turbine parts.	15.00-17.5	3.00-5.00	.07	1.00	.03	Cu 3.0-5.0 Cb+Ta .15-.45
	17Cr-4Ni H1150 (S17400)	5643 2303	A-564 (Type 630)		SA-564 (Type 630)	—	Age-hardened 17Cr-5Ni H1150 offers superior machinability when compared to condition A 17Cr-4Ni. Buying this product in the age-hardened condition also saves the time and additional expense of sending parts out for heat treatment.	15.00-17.50	3.00-5.00	.07	1.00	.03	Cu 3.0-5.0 Cb+Ta .15-.45
	17Cr-4Ni Double-Aged H1150 (S17400)	5643 ⁽⁸⁾	A-564 (Type 630) API 6A NACE MR-01-91		SA-564 (Type 630)	—	It is solution annealed and then double age-hardened. Use in oil field valves, pump shafts, paper mill equipment gears.	15.00-17.50	3.00-5.00	.07	1.00	.03	Cu 3.0-5.0 Cb+Ta .15-.45

(1) Castle's stainless is ordered to these specifications, however there are some restrictions by size, shape, and availability. Give us your specifications to properly service your needs.

(2) All values are maximum except as noted.

(3) This column is provided for your convenience. A.M. Castle & Co. cannot and does not make recommendations of type or grade of material for end use. Proper selection of material for proposed end use is our customer's responsibility.

(4) Abbreviations:

Cb—Columbium
Cu—Copper
Mo—Molybdenum
N—Nitrogen





S—Sulfur
Ta—Tantalum
Ti—Titanium

WQ—Water Quench
AC—Air Cool
O—Oil Quench

L—Longitudinal
T—Transverse

Stainless Steel Bars



TYPICAL MECH. PROPERTIES					SIZE RANGE—INCHES						TYPE
Tensile 10 ³ P.S.I.	Yield 10 ³ P.S.I. .2% Offset	Elongation % 2 in.	Reduction in Area %	Hardness Brinell	Rounds 	Hexagons 	Squares 	Flats 	Angles 	AISI TYPE Unified Numbering System (UNS)	
75	40	35	70	155	1/2–7-1/2	—	—	—	—	410 (S41000)	
100	80	17	35	241 Max.	2–15	—	—	—	—	410 Quench & Dbl Temp.	
75	40	30	60	155	3/32–6-1/2	3/8–2	3/16–2	—	—	416 ⁽⁶⁾ (S41600)	
—	—	—	—	—	1/4–7	—	—	—	—	416HT (S41600)	
110	65	14	25	230	1/4–8	—	—	—	—	440C (S44004)	
—	—	—	—	—	1/2–6	—	—	—	—	440C BQ ⁽⁷⁾ (S44004)	
100	85	20	46	262	5/8–3-7/16	—	—	—	—	416 Pump Shaft (S41600)	
100	80	20	40	241	3-1/4–9	—	—	—	—	420 Modified	
90	65	25	—	290	1–10	—	—	—	—	2205 (S31803)	
109–145	80	25	—	285	3-1/2–6-1/2	—	—	—	—	2507 (S32750)	
160	120	17	65	300	1/2–4	—	—	—	—	13Cr-8Ni ⁽⁷⁾ (S13800)	
160	145	15	—	332	1/4–8	—	—	—	—	15Cr-5Ni ⁽⁷⁾ (S15500)	
—	—	—	—	332	3/16–20	—	—	—	—	17Cr-4Ni ⁽⁷⁾ (S17400)	
160	145	15	—	311	1/2–8	—	—	—	—	17Cr-4Ni H1150 (S17400)	
130	105	16	50	310	1/2–9	—	—	—	—	17Cr-4Ni Double-Aged H1150 (S17400)	

(5) Edge conditioned flats chemical and mechanical properties to apply.

(6) Also stocked as pump shafting.
Tensile strength 90/120,000 P.S.I.
Yield Strength 70,000 P.S.I. min.
Hardness—Approximately Brinell 207/245

(7) Mechanical properties are typical for solution treated condition. (Cond. A)
(8) Chemistry only.

(9) This section of 300 Series marked WQ (AC) are usually air cooled to minimize distortion, heavier section water quenched.
(10) Charpy V Notch.

(11) Solution treating temperature.

(12) Available 17Cr–4Ni Single Aged H1150.

(13) Properties are longitudinal and transverse direction except where indicated.

(14) Properties are taken longitudinal, transverse properties on 15Cr–5Ni are similar for tensile and yield strength.

The information in this quick guide is correct to the best of our knowledge. A.M. Castle & Co. assumes no responsibility for errors or omissions. A.M. Castle & Co. publishes this quick guide for guidance of their customers and reserves the right to add or delete items without notification.

Precipitation Hardening Grades

Unique alloys which offer corrosion resistance that approaches Type 304. The general corrosion resistance is greatest in the fully hardened condition. The alloys can obtain a wide range of mechanical properties with low temperature precipitation hardening (aging).

Typical Mechanical Properties

	13Cr-8Ni ⁽¹³⁾							13Cr-8Ni							
	RH950	H950	H100	H1050	H1100	H1150	H1150M	H900	H925	H1025	H1075	H1100	H1150	DBL H1150	H1150M
Tensile x 10 ³ P.S.I.	235	225	215	190	160	145	130	200	190	170	165	150	145	130	125
Yield x 10 ³ P.S.I. 2% Offset	215	210	20	180	150	105	85	185	175	165	150	135	125	105	85
Elongation % in 2"	12	12	13	15	18	20	22	14	14	15	16	17	19	20	22
Reduction in Area %	⁽⁴⁾ L-45 ⁽⁴⁾ T-35	⁽⁴⁾ L-50 ⁽⁴⁾ T-40	⁽⁴⁾ L-55 ⁽⁴⁾ T-50	55	60	63	70	50	54	56	58	58	60	64	68
Impact Value Charpy V Notch Ft.-lb.	20	30	40	60	100	110	120	20	25	35	40	45	50	—	100
Hardness Brinell	453	443	422	400	336	310	273	420	409	352	341	332	311	—	277

Precipitation Hardening Treatment

Alloy	Condition	Aging Temperature °F	Time at Temperature (Hrs.)	Method of Quench
13Cr-8Ni	RH950* H950 H1000 H1050 H1100 H1150 H1150M	All Temp. ±10°F		
		950	4	Air Cool
		950	4	Air Cool
		1000	4	Air Cool
		1050	4	Air Cool
		1100	4	Air Cool
		1150	4	Air Cool
		1400	2	Air Cool
		Plus 1150	4	Air Cool
15Cr-5Ni 17Cr-4Ni	H900 H925 H1025 H1075 H1100 H1150 DBL H1150 H1150M	All Temp. ±15°F		
		900	1	Air Cool
		925	4	Air Cool
		1025	4	Air Cool
		1075	4	Air Cool
		1100	4	Air Cool
		1150	4	Air Cool
		1150	4	Air Cool
		1150	4	Air Cool
		1400	2	Air Cool
		1150	4	Air Cool

* Within 24 hours of solution treatment, cool to -100°F for two hours minimum, air warm and age as shown.

Tolerances—Stainless Steel Bars

ROUNDS

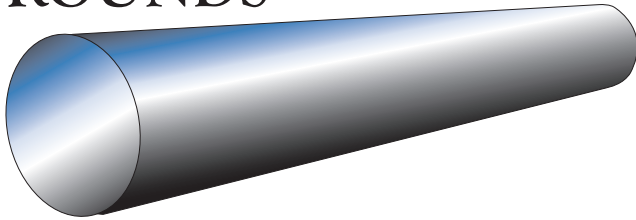

ROUNDS—COLD FINISHED	
Under 5/16	±.001
5/16 to Under 1/2	±.0015
1/2 to Under 1	±.002
1 to Under 1-1/2	±.0025
1-1/2 to 4 Incl.	±.003
Over 4 to 4-1/2 Incl.	±.005
Over 4-1/2 to 6 Incl.	±.008

SQUARES

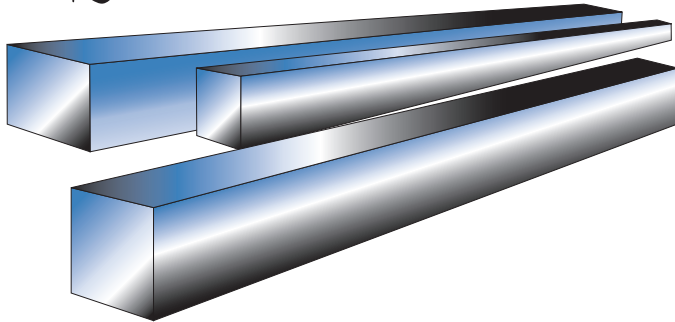

ROUNDS—HOT ROLLED & ROUGH TURNED		
Over 2 to 2-1/2	+1/32 -0	Out of Rd. 0.23
Over 2-1/2 to 3-1/2	+3/64 -0	.035
Over 3-1/2 to 4-1/2	+1/16 -0	.046
Over 4-1/2 to 5-1/2	+5/64 -0	.058
Over 5-1/2 to 6-1/2	+1/8 -0	.070
Over 6-1/2 to 8	+5/32 -0	.085
Over 8 to 12	+3/16 -0	.093
Over 12 to 15	+7/32 -0	.109
Over 15 to 20	+1/4 -0	.125

HEXAGONS

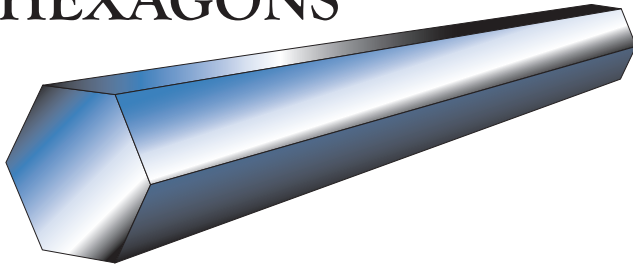

SQUARE AND HEXAGON—COLD FINISHED	
Under 5/16	±.000-.002
5/16 to Under 1/2	±.000-.003
1/2 to 1 Incl.	±.000-.004
Over 1 to 2 Incl.	±.000-.006
Over 2 to 3 Incl.	±.000-.008
Over 3	±.000-.011

STRAIGHTNESS TOLERANCE	
Hot Finished 1/8 Inch in Any 5 Ft., But May Not Exceed $1/8 \times \frac{\text{No. of Feet in Length}}{5}$	Cold Finished 1/16 Inch in Any Ft., But May Not Exceed $1/16 \times \frac{\text{No. of Feet in Length}}{5}$
PUMP SHAFTING	
.005 TIR n 3 ft. Plus .0015 TIR for Each Ft. Over 3 Ft.	
*Straightness is a Perishable Tolerance and Will be Maintained Only on Product of a Full Stock Box.	

PUMP SHAFT QUALITY		
	Diameter Over	Tolerance Under
3/4 to Under 1	+0.000	-.002
1 to Under 1-1/2	+0.000	-.0025
1-1/2 to 4 Incl.	+0.000	-.003
Over 4 to 4-1/2	+0.000	-.005
Over 4-1/2 to 5 Incl.	+0.000	-.008

Specializing in Supply Chain Solutions

CALL 800.BUY.CSTL (289-2785) FOR
THE CASTLE LOCATION NEAR YOU



Castle Metals®